

# EXTEND CONNECTION BALL VALVE – With High Position Pad

## N-3MDBL

### Technical Data

**Full Port, 3 piece type**

**Material:** Wetted parts ASTM A351 CF8M / 316

**Connection Size:** ¼" (8mm), ⅜" (10mm), ½" (15mm), ¾" (20mm), 1" (25mm), 1¼" (32mm), 1½" (40mm), 2" (50mm), 2½" (65mm), 3" (80mm), 4" (100mm)

**Connection Type:** Long butt weld ends

**ISO 5211 Mounting Pad- High position pad**

**Locking Device:** Valve operated locking in open or closed position

**Working Temperature Limited:** -20°F ~ 350°F (-5°C ~ 175°C)

**Working Pressure Limited:** 1000psi (70kg/cm<sup>2</sup>) for ¼"~1"; 800psi (56kg/cm<sup>2</sup>) for 1¼"~2"; 600psi (42kg/cm<sup>2</sup>) for 2½"~4"

Valves inspected and tested according to **API 598 standard**.



### Dimensions

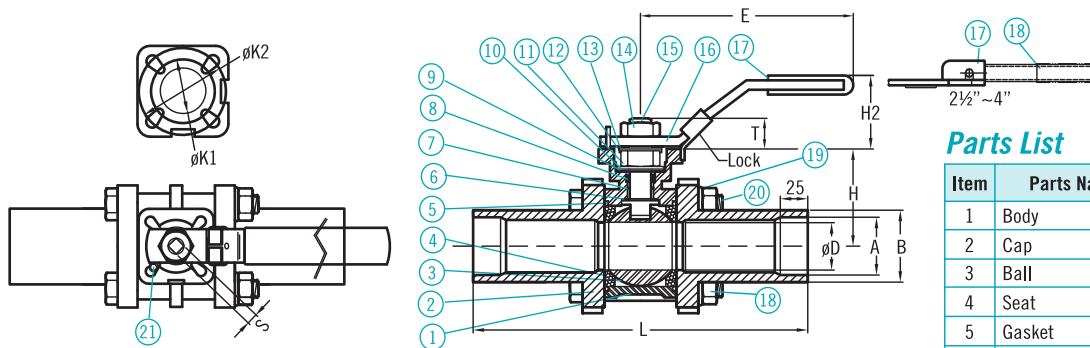

unit=mm

mm	Size inch	øD	L±1.0	H±0.5	E±3.0	T	S	H2±3.0	A±0.3	B±0.3	ISO5211		TORQUE Inch/Lbs
											øK1	øK2	
08	¼	11.6	160	38	143	9	9	26	13.5	16.8	F03	F04	50
10	⅜	12.6	160	38	143	9	9	26	13.5	16.8	F03	F04	50
15	½	15	180	38	143	9	9	26	18.3	21.3	F03	F04	50
20	¾	20	180	47	143	9	9	26	23.7	26.9	F03	F04	80
25	1	25	192	57.2	160	11	11	32	30.1	33.7	F04	F05	100
32	1¼	32	205	62.5	160	11	11	32	38.4	42.4	F04	F05	280
40	1½	38	230	77.5	187	14	14	42	44.3	48.3	F05	F07	300
50	2	50	243	86.5	187	14	14	42	55.3	60.3	F05	F07	350
65	2½	65	294	108	350	17	17	32	70.1	76.1	F07	F10	500
80	3	80	320	115	350	17	17	32	83.1	89.1	F07	F10	750
100	4	100	346	135	350	22	22	37	108.6	114.6	F10	F12	1000

### Parts List

Item	Parts Name	Material
1	Body	ASTM A351 CF8M / 316
2	Cap	ASTM A351 CF8M / 316
3	Ball	ASTM A351 CF8M / 316
4	Seat	PTFE
5	Gasket	PTFE
6	Thrust Washer	PTFE
7	O-Ring	Viton
8	Stem Packing	PTFE
9	Gland	AISI 304
10	Belleville Washer	AISI 304
11	Stem Nut	AISI 304
12	Lock Saddle	AISI 304
13	Gland	AISI 304
14	Stem Nut	AISI 304
15	Stem	ASTM A276 316
16	Handle	AISI 304
17	Handle Grip	VINIL Plastisol
18	Bolt Nut	AISI 304
19	Bolt Washer	AISI 304
20	Bolt	AISI 304
21	Stop Poer Nut	AISI 304

### Pressure–Temperature

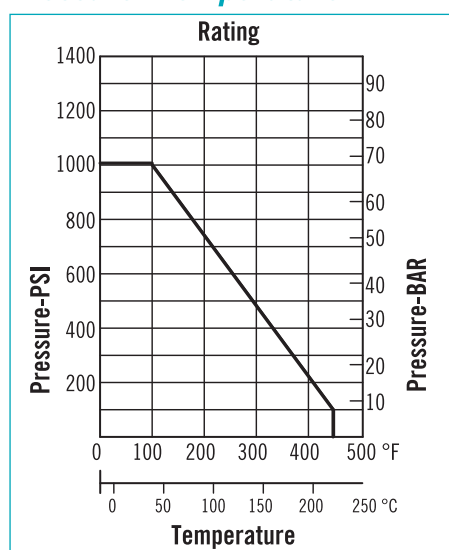

### Ordering Information

N-3MDBL	Code	Model
	L	Long Butt Weld Ends
	S	CF8M / SS316
	(A) ¼" (B) ⅜" (C) ½" (D) ¾" (E) 1" (F) 1¼"	Code Connection Size
	(G) 1½" (H) 2" (I) 2½" (J) 3" (K) 4"	
N-3MDBL		Complete Ordering Code